

MEETING IN







RESISTANCE TO FLAMMABILITY AND ADVERSE ATMOSPHERIC CONDITIONS

The structures are realized by highly resistant extruded profiles, solid casted joints and exclusive use of primarily aluminium alloys.

The roof covers are made of highly resistant PVC fabric, equipped with flame retardant certificates.

All our coverings are provided with static calculation reports in compliance with safety regulations in force.

RESISTENZA AGLI AGENTI ATMOSFERICI AVVERSI E AL FUOCO.

Le strutture sono realizzate con resistenti profilati estrusi e solidi giunti in fusione con utilizzo esclusivo di leghe primarie di alluminio. Le membrane di copertura utilizzate sono in tessuto PVC ad alta resistenza, corredate di certificazioni di ignifugazione. Tutte le strutture sono provviste di relazione di calcolo statico in conformità alle vigenti normative di sicurezza.



FUNCTIONAL ASSEMBLING

Special joints, fast connection type, to be coupled to the relevant profiles, enable the easy and effective assembling of the structures.

PRATICITA' DI MONTAGGIO

Giunti speciali ad innesto rapido, accoppiati ai relativi profili, permettono di assemblare le strutture in modo semplice e pratico.



COVERINGS MODULARITY

All structures have been designed to be freely combined in different shapes and sizes by means of special guttering systems and proper special fastening brackets. Whenever the structures are linked together they are fully water tight.

MODULARITA' DELLE COPERTURE

Tutti i modelli delle strutture sono stati progettati per essere uniti fra loro nelle diverse forme e dimensioni mediante un particolare sistema di unioni con grondaie e staffe speciali. Le coperture aggregate fra loro sono a tenuta d'acqua piovana.



EASY TRANSPORT

The structures are delivered partially assembled, in properly separate and accurate packing, to enable the best handiness during the handling and transport phases.

FACILITA' DI TRASPORTO

Le strutture vengono spedite parzialmente assemblate, in appositi ed accurati imballi separati fra loro per consentire la massima maneggevolezza durante le fasi di movimentazione e trasporto.



LONG LASTING

All materials used for manufacturing the structures and the roof covers are of primary quality and are subject to special treatments to be long lasting.

DURATA NEL TEMPO

Tutti i materiali utilizzati per la costruzione delle strutture e delle coperture, oltre ad essere di primaria qualità, vengono sottoposti a trattamenti speciali che li rendono durevoli nel tempo.



INSIDE COMFORT

Our structures have been designed to offer a comfortable and pleasant interior environment.

It's possible to install a wide range of optionals such as: lining, aluminium flooring, lighting, heating, ventilation, rigid and sliding side walls, equipped with double glazing on request.

CONFORT INTERNO

Le strutture realizzate sono state studiate per offrire un ambiente interno confortevole e gradevole.

E' possibile infatti installare una vasta gamma di optionals quali controsoffitto, pavimentazione in alluminio, illuminazione, riscaldamento, ventilazione, pareti laterali rigide a pannelli scorrevoli, dotate anche di vetrocamera.

MEETING IN

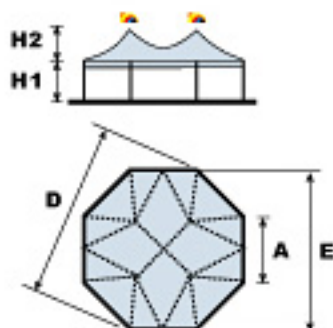

A (cm)	H1 (cm)	H2 (cm)	AREA (m ²)	D (cm)	E (cm)
500	*	260	120,0	1305	1205
600	*	310	174,0	1570	1450



* = the tent is supplied with static calculations for max height 300 cm.
* la struttura è fornita di calcoli statici fino ad un'altezza utile massima di cm 300.

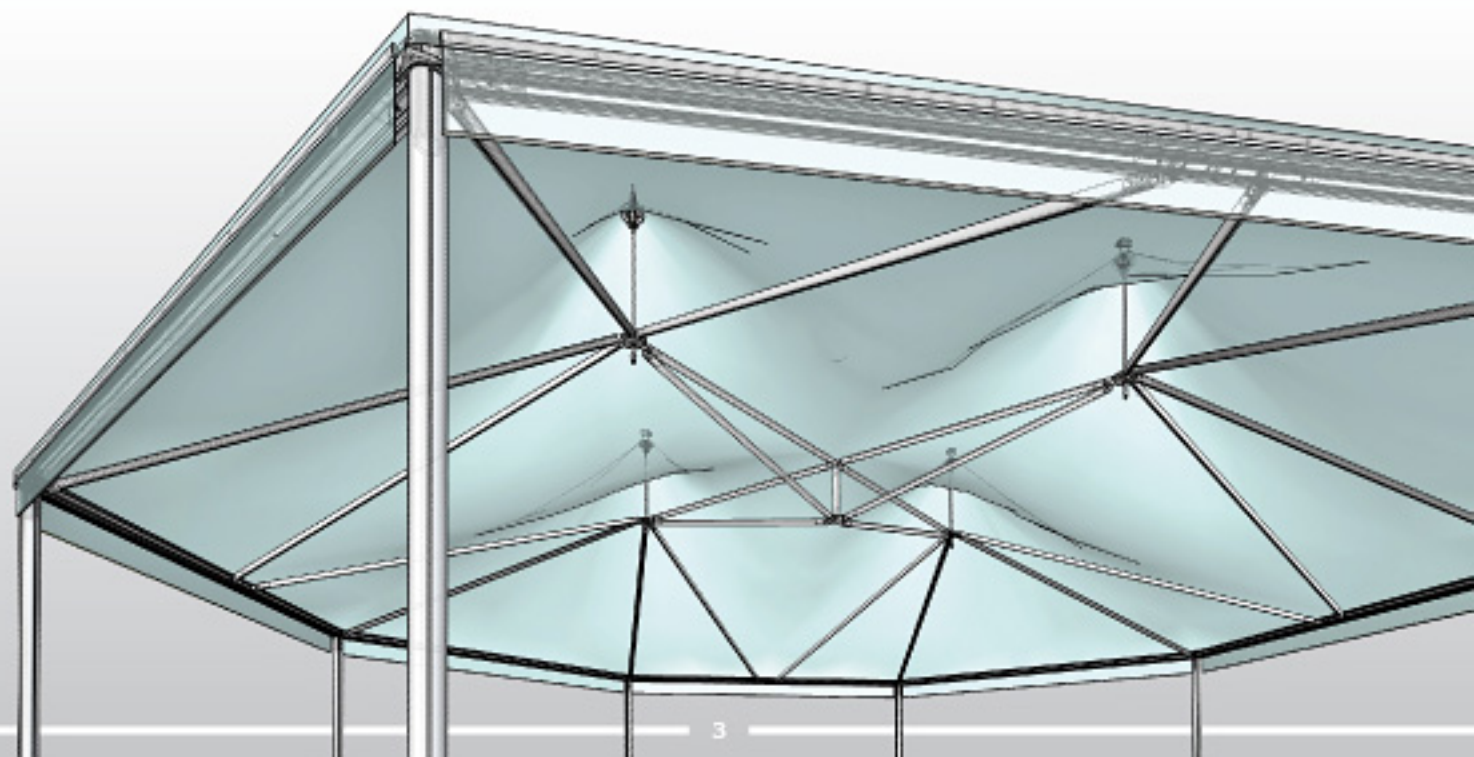
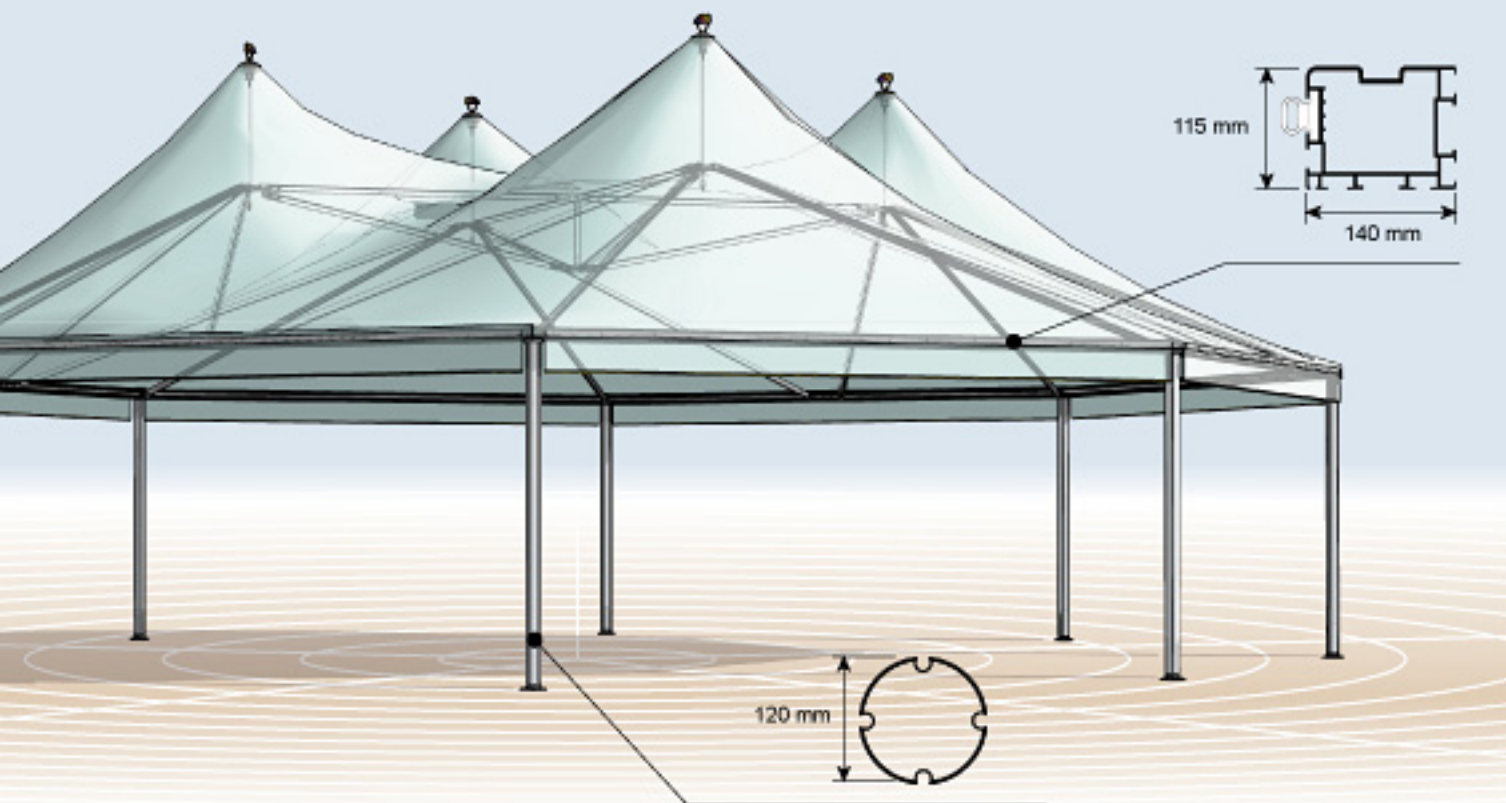

1

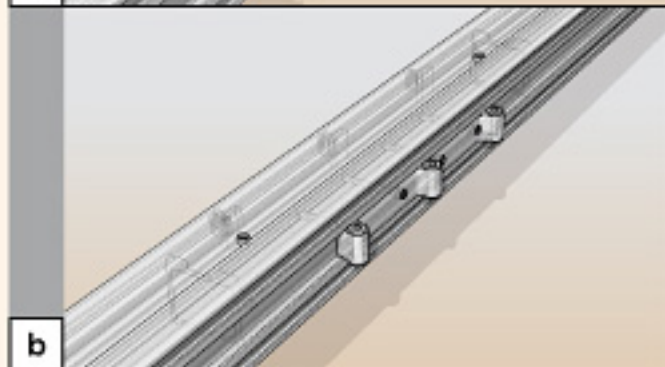
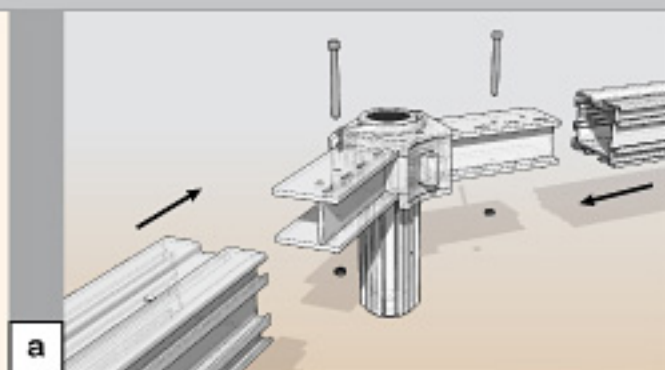

2

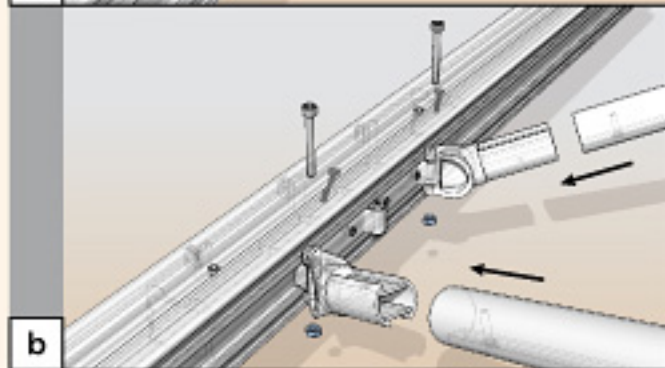
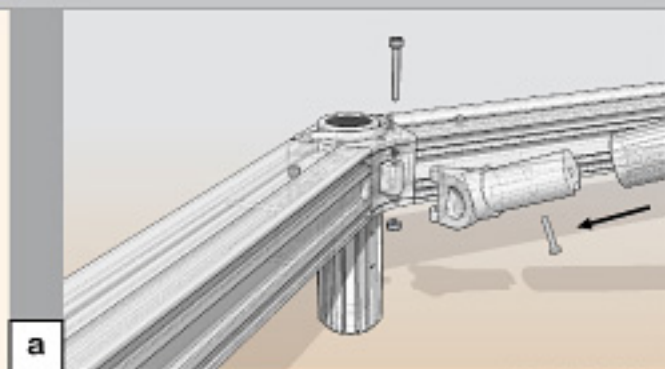
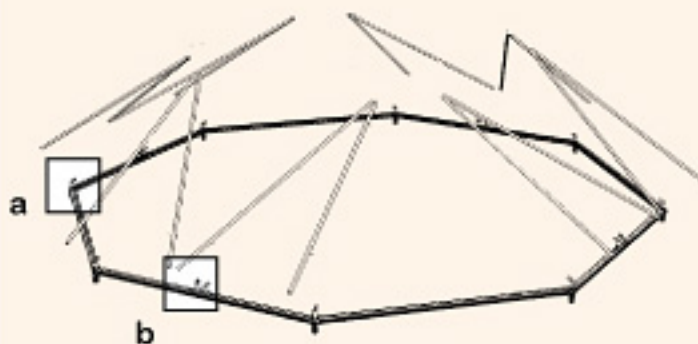

3

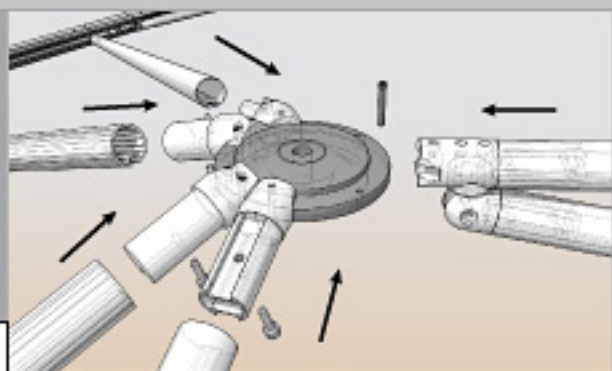
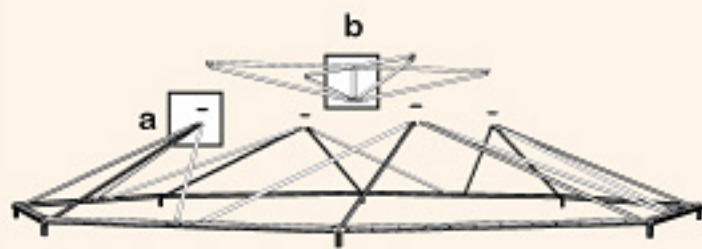

a

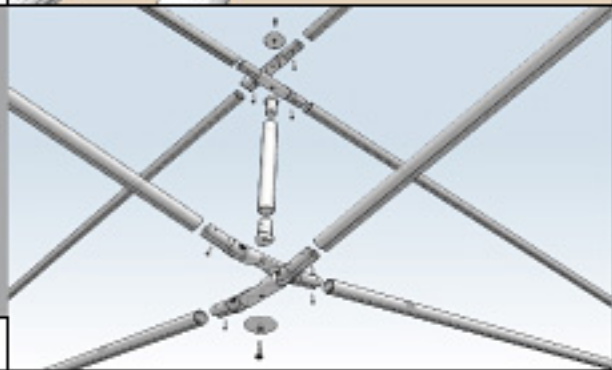

b

4

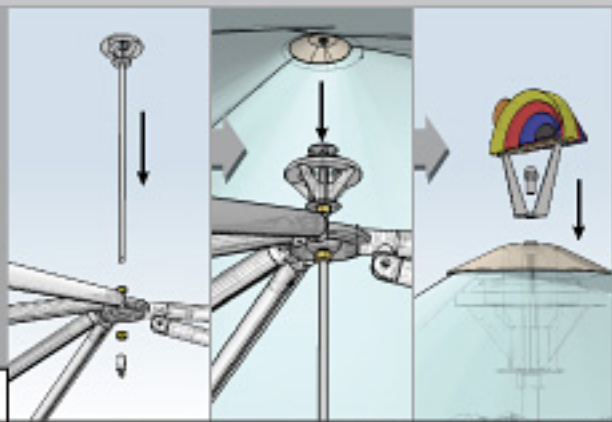
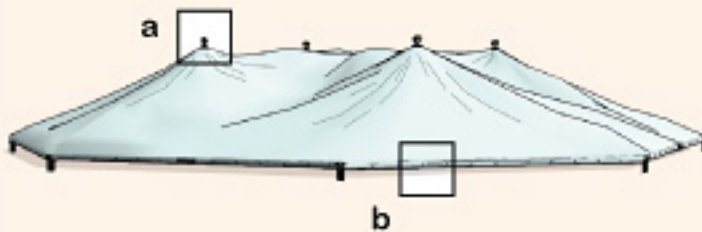

a

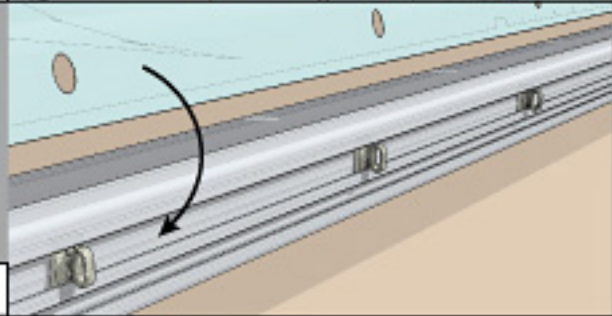

b

5

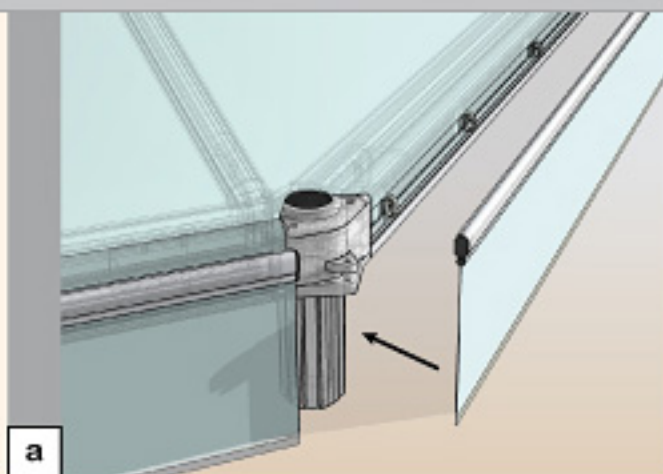
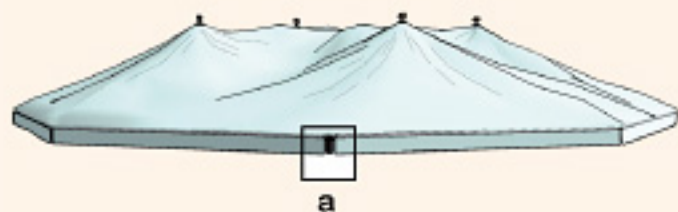

6

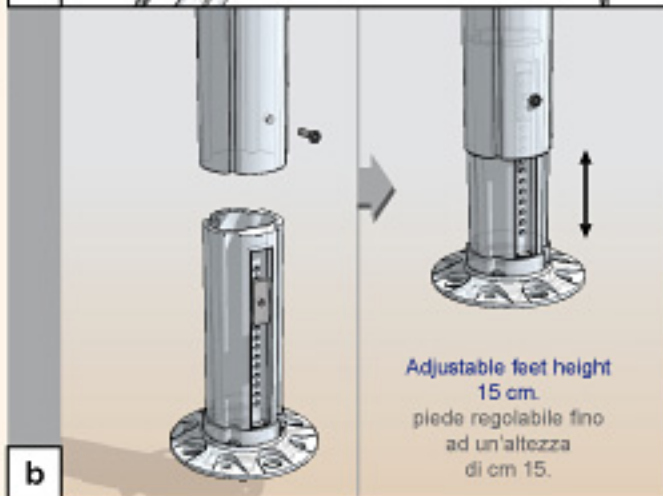
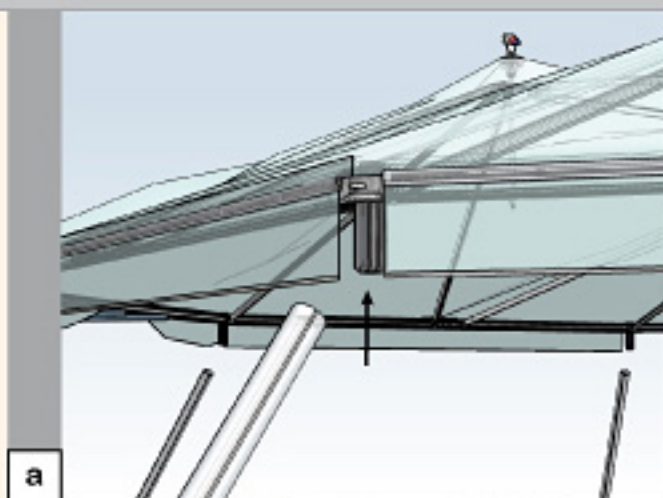
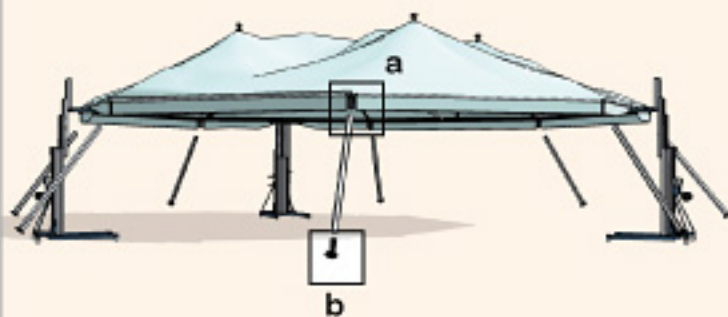

7

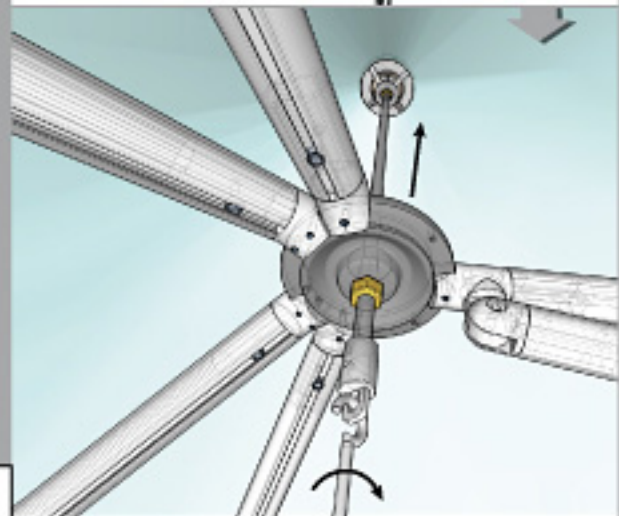
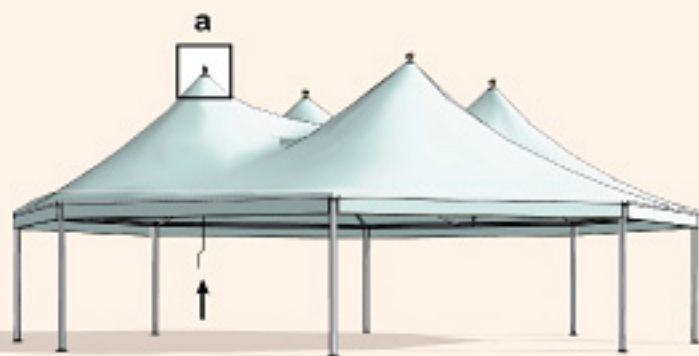

**JUNCTION FILLER
COPRIFESSURA**

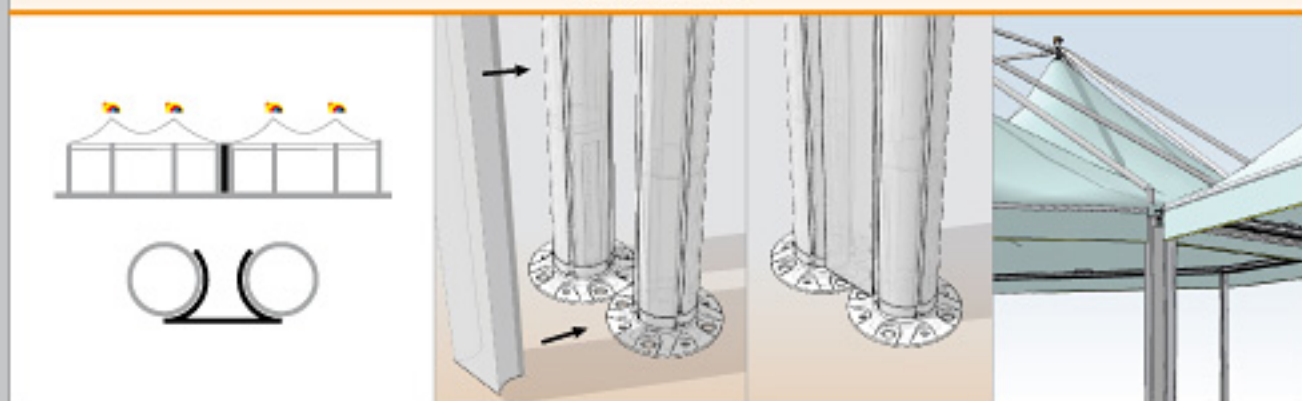

**KIT FOR MODULES CONNECTION
KIT UNIONE MODULI**

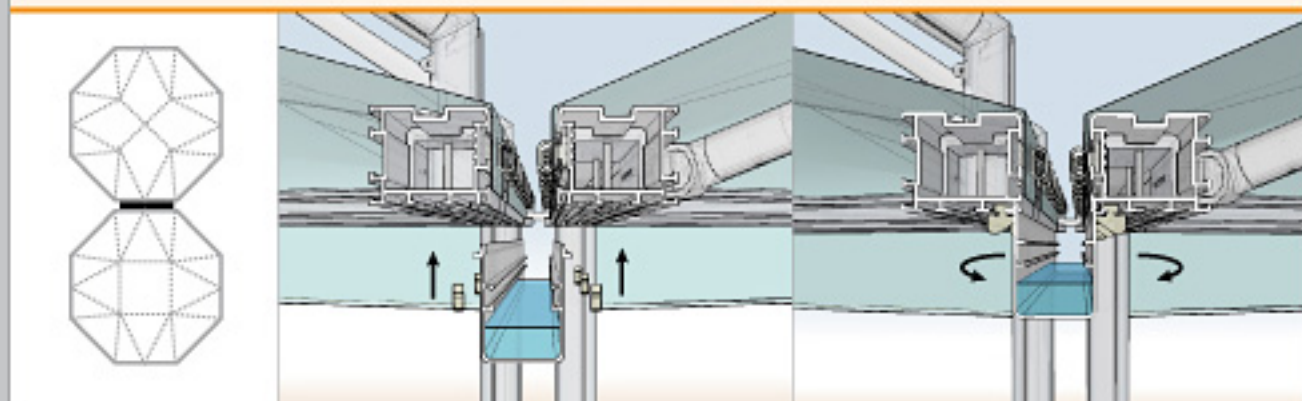

**CENTRAL JOINT
GIUNTO CENTRALE**

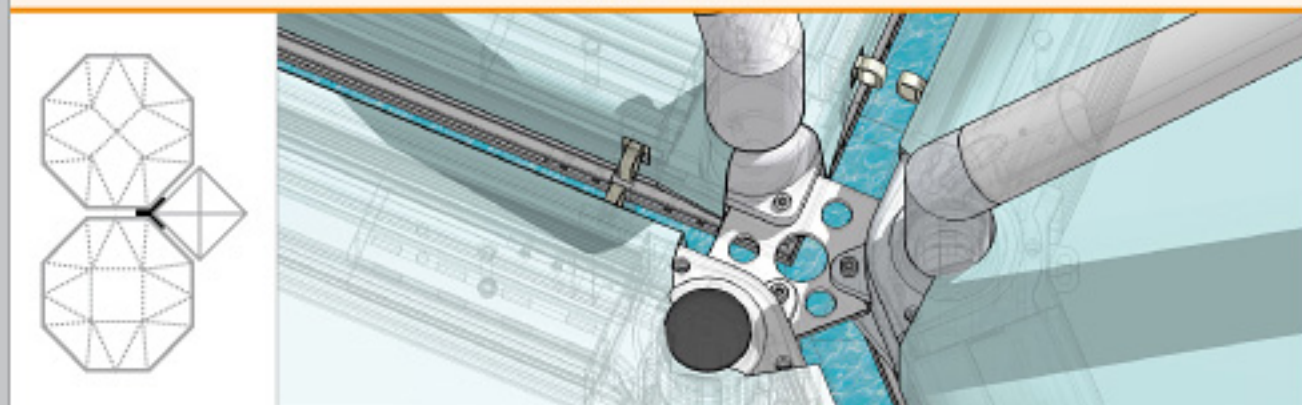



GIULIO BARBIERI
Special Modular Coverings

Giulio Barbieri S.p.A.
Via Ferrara, 41.
44028 Poggio Renatico (FE).
Tel. (+39) 05 32 82 15 11
Fax. (+39) 05 32 82 15 55

